

SCM 010-130 ISO is a range of robust axial piston motors especially suitable for mobile hydraulics.

SCM 010-130 ISO is of the bent-axis type with spherical pistons. The design results in a compact motor with few moving parts, high starting torque and high reliability. It covers the entire displacement range 10-130 cm³/rev. at a maximum pressure of 400 bar. The motors well dimensioned, double tapered roller bearings which permit high shaft loads and lead to excellent speed characteristics. The high level of reliability is based on the choice of materials, hardening methods, surface structures and the quality assured manufacturing process.

Other advantages:

- High maximum speed
- Smooth operation over the entire speed range
- Available in many different configurations of shafts and connections
- High efficiency
- Speed sensor available as option
- Suitable for applications with high angular accelerations due to its high rotary stiffness

Versions, main data

Example

SC	M	010	W	P	I41	W25	K3	G	1	00
Line	1	2	3	4	5	6	7	8	9	10

Line	SC	Sunfab Compact, bent-axis design
------	----	----------------------------------

1. Type	M	Motor
---------	---	-------

2. Displacement	010	012	017	025	034	040	047	056	064	084	090	108	130
-----------------	-----	-----	-----	-----	-----	-----	-----	-----	-----	-----	-----	-----	-----

3. Direction of rotation	W	Independent
--------------------------	---	-------------

4. Shaft seal	P	FPM, high pressure, high temperature
---------------	---	--------------------------------------

For low temperature applications, below -25 °C please contact Sunfab.

5. Mounting flange	ISO 3019-2	010	012	017	025	034	040	047	056	064	084	090	108	130
I41	ISO 4-h ø80	X	X	X	-	-	-	-	-	-	-	-	-	-
I42	ISO 4-h ø100	-	O	O	X	X	-	-	-	-	-	-	-	-
I43	ISO 4-h ø125	-	-	-	-	-	X	X	X	X	-	-	-	-
I44	ISO 4-h ø140	-	-	-	-	-	-	-	-	-	X	X	O	O
I45	ISO 4-h ø160	-	-	-	-	-	-	-	-	-	O	O	X	X

- = Not available
X = Standard, preferred
O = Contact Sunfab

6. Shaft	Spline DIN 5480	010	012	017	025	034	040	047	056	064	084	090	108	130
W20	W20x1.25x14x9g	X	X	X	-	-	-	-	-	-	-	-	-	-
W25	W25x1.25x18x9g	X	X	X	X	(X)	-	-	-	-	-	-	-	-
W30	W30x2x14x9g	-	-	-	X	X	X	X	X	(X)	-	-	-	-
W32	W32x2x14x9g	-	-	-	-	-	X	X	X	(X)	-	-	-	-
W35	W35x2x16x9g	-	-	-	-	-	X	X	X	X	X	X	-	-
W40	W40x2x18x9g	-	-	-	-	-	-	-	-	-	X	X	X	X
W45	W45x2x21x9g	-	-	-	-	-	-	-	-	-	O	O	X	X
Key DIN 6885														
K20	ø 20 k6	X	X	X	-	-	-	-	-	-	-	-	-	-
K25	ø 25 k6	X	X	X	X	(X)	-	-	-	-	-	-	-	-
K30	ø 30 k6	-	O	O	X	X	X	X	X	(X)	-	-	-	-
K35	ø 35 k6	-	-	-	-	-	X	X	X	X	-	-	-	-
K40	ø 40 k6	-	-	-	-	-	-	-	-	-	X	X	O	O
K45	ø 45 k6	-	-	-	-	-	-	-	-	-	O	O	X	X

- = Not available
X = Standard, preferred
O = Contact Sunfab
(X) = Limited maximum pressure, contact Sunfab

7. Connection cover		010	012	017	025	034	040	047	056	064	084	090	108	130
S1	40° Mount flange vertical *	-	-	-	-	-	-	-	-	-	X	X	X	X
S2	40° Mount flange horizontal *	-	-	-	X	X	X	X	X	X	-	-	-	-
S3	40° Threaded connection	X	X	X	X	X	-	-	-	-	-	-	-	-
V1	90° Mount flange vertical *	-	-	-	-	-	-	-	-	-	X	X	X	X
V2	90° Mount flange horizontal *	-	-	-	X	X	X	X	X	X	X	X	X	X
R1	Side connections, flanged *	-	-	-	X	X	X	X	X	X	X	X	X	X
K3	Combicover 90° side conn. thread	X	X	X	X	X	-	-	-	-	-	-	-	-

* According to SAE J518 code 62

8. Connections		010	012	017	025	034	040	047	056	064	084	090	108	130
G	ISO G*	X	X	X	X	X	-	-	-	-	-	-	-	-
M	Metric **	-	-	-	X	X	X	X	X	X	X	X	X	X
U	UN***	X	X	X	X	X	X	X	X	X	X	X	X	X

* Only threaded connections
** Only flanged connections
*** Not available for K3

9. Additional	1	External drainage
---------------	---	-------------------

10. Speed Sensor		010	012	017	025	034	040	047	056	064	084	090	108	130
00	No Speed Sensor	X	X	X	X	X	X	X	X	X	X	X	X	X
P1	Prepared for Speed Sensor	X	X	X	X	X	X	X	X	X	X	X	X	X
S1	Fitted Speed Sensor type PNP*	X	X	X	X	X	X	X	X	X	X	X	X	X
S2	Fitted Speed Sensor type NPN*	X	X	X	X	X	X	X	X	X	X	X	X	X

* See separate brochure "Speed Sensor hall" for more information.

SCM 010-130 ISO		010	012	017	025	034	040	047	056	064	084	090	108	130
Displacement	cm ³ /rev	9.6	12.6	17.0	25.4	34.2	41.2	47.1	56.7	63.5	83.6	90.7	108.0	130.0
Working pressure														
<i>max intermittent</i>	bar	400	400	400	400	400	400	400	400	400	400	400	400	350
<i>max continuous</i>		350	350	350	350	350	350	350	350	350	350	350	350	300
Revolutions														
<i>max intermittent</i>	rpm	8800	8800	8800	7000	7000	6300	6300	6300	6300	5200	5200	5200	5200
<i>max continuous</i>		8000	8000	8000	6300	6300	5700	5700	5700	5700	4700	4700	4700	4700
<i>min continuous</i>		300	300	300	300	300	300	300	300	300	300	300	300	300
Power														
<i>max intermittent</i>	kW	41	54	74	86	115	125	145	175	195	215	230	275	285
<i>max continuous</i>		15	20	25	40	55	60	65	80	90	100	110	130	135
Starting torque theoretical value	Nm/bar	0.15	0.20	0.27	0.40	0.54	0.66	0.75	0.89	1.00	1.33	1.44	1.71	2.06
Moment of inertia (x 10 ⁻³)	kg m ²	0.9	0.9	0.9	1.1	1.1	2.6	2.6	2.6	2.6	7.4	7.4	7.4	7.4
Weight	kg	8.5	8.5	8.5	9.5	9.5	16.5	16.5	16.5	16.5	28.0	28.0	30.5	30.5

Data concerning RPM are based on maximum permitted peripheral velocity of the tapered roller bearing.
 Max intermittent power data may vary dependent on application. For further information please contact Sunfab.
 Continuous power data are based on maximum output power without external cooling of the motor housing.
 Intermittent duty is defined as follows: max 6 seconds per minute, e.g. peak RPM when unloading or accelerating.

Dimensions SCM 010-017

Flange & shafts

Millimeter (inch)

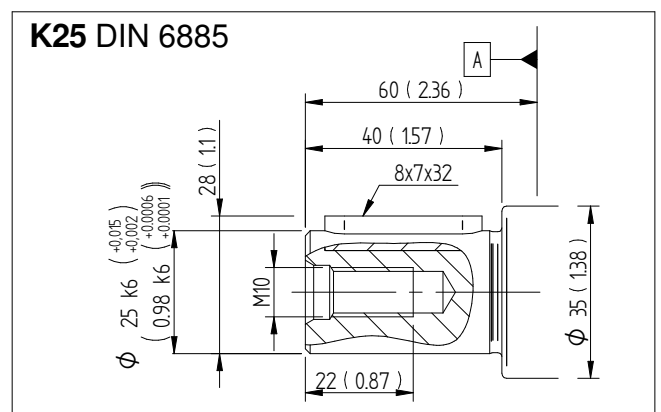
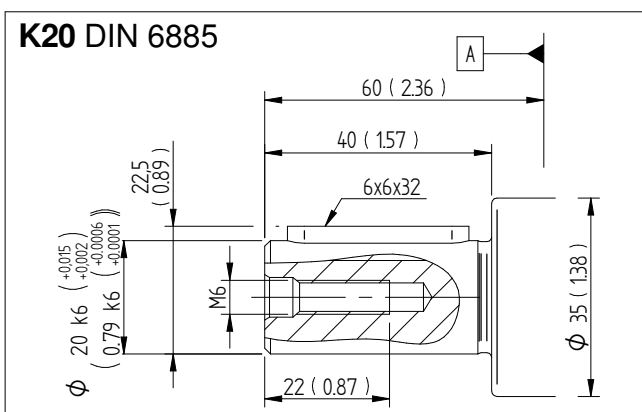
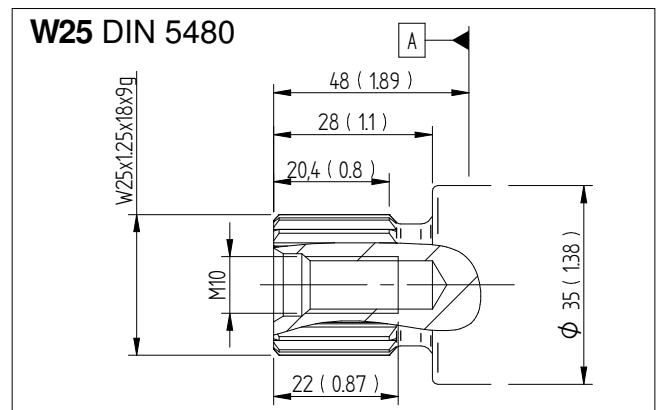
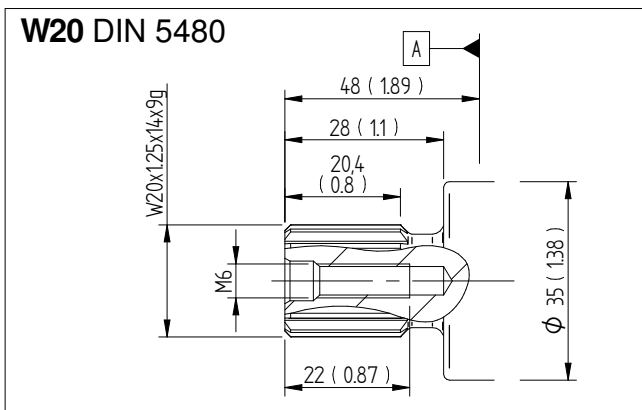
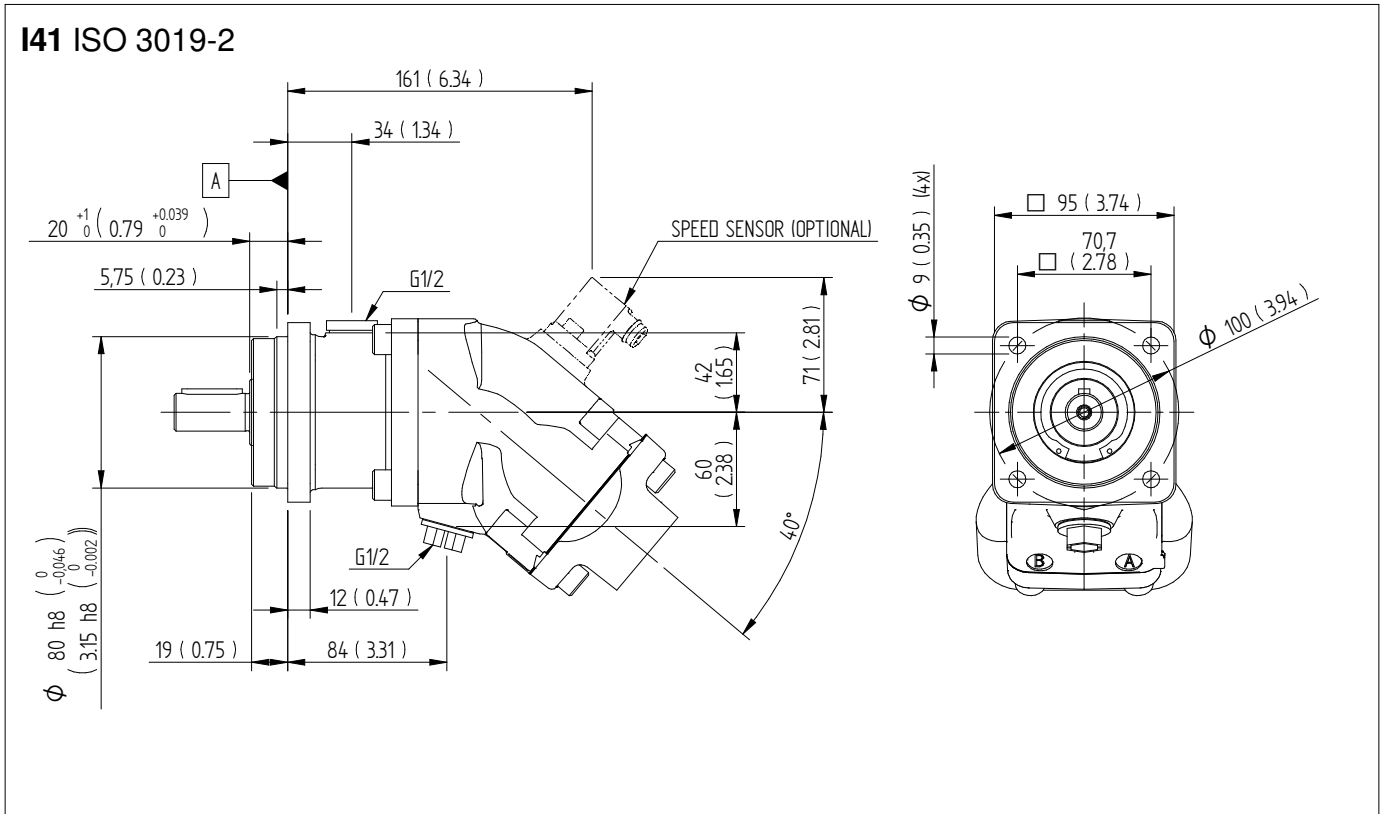

Dimensions SCM 010-017

Connection cover

Millimeter (inch)

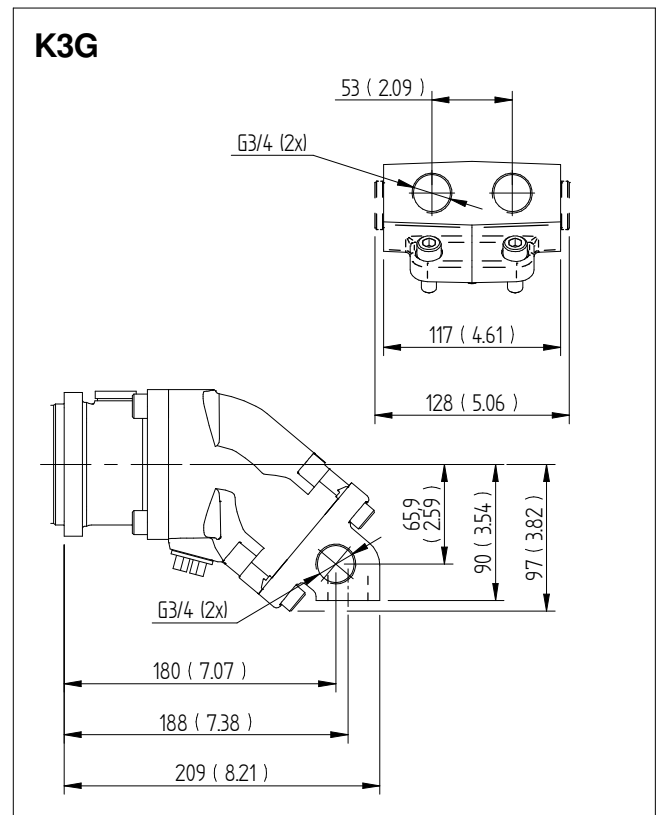
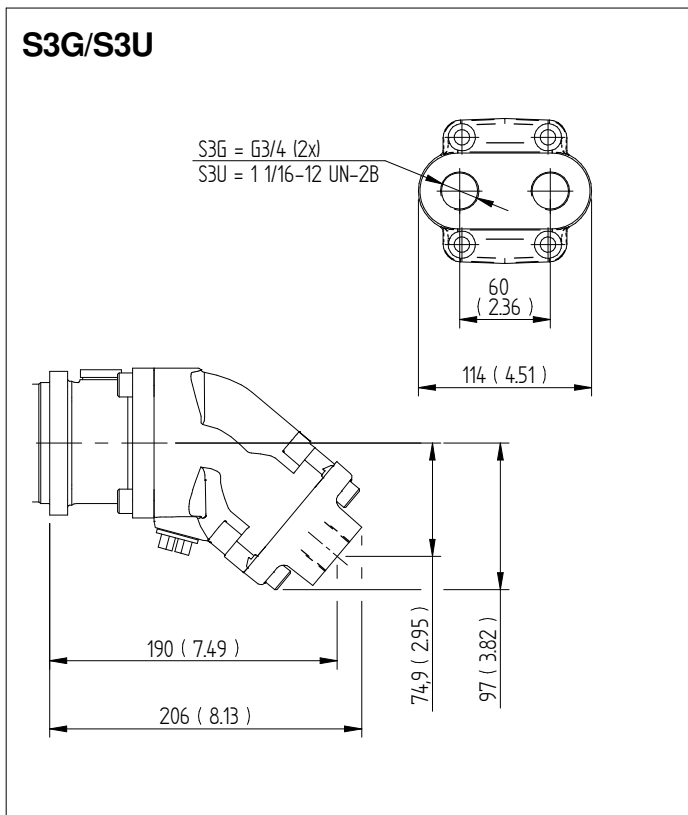

Dimensions SCM 025-034

Flange & shafts

Millimeter (inch)

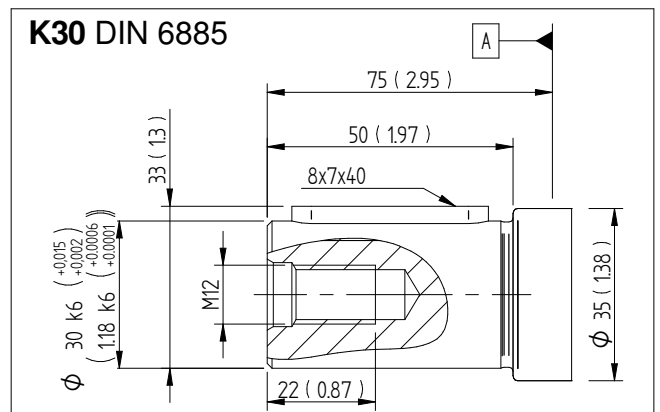
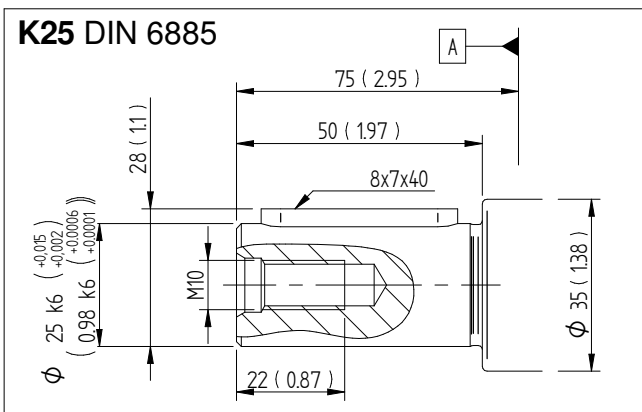
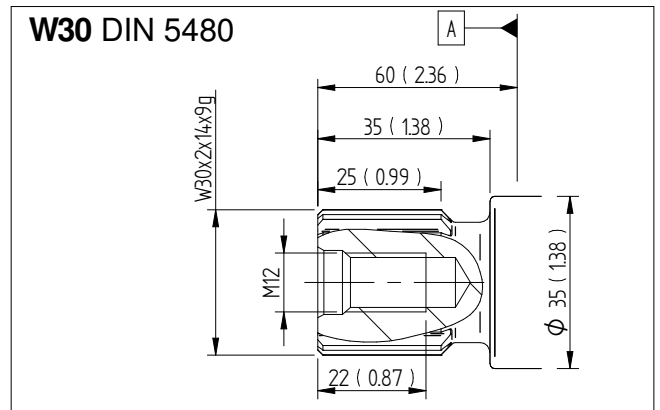
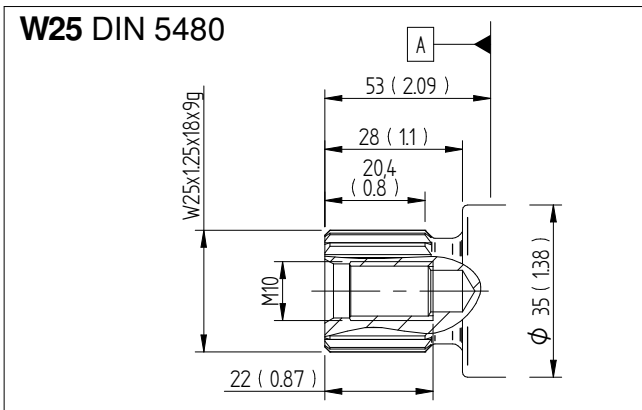
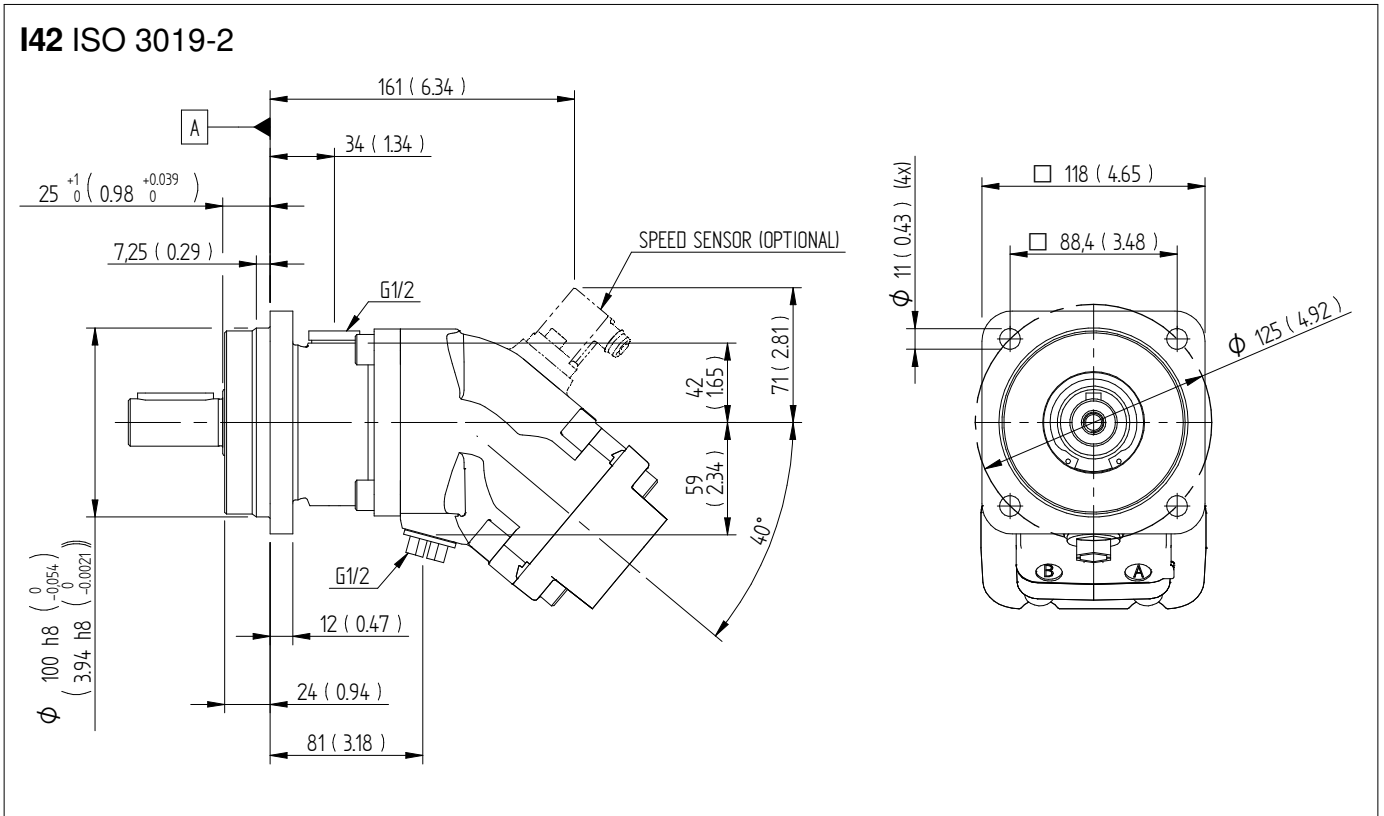

Dimensions SCM 025-034

Connection cover

Millimeter (inch)

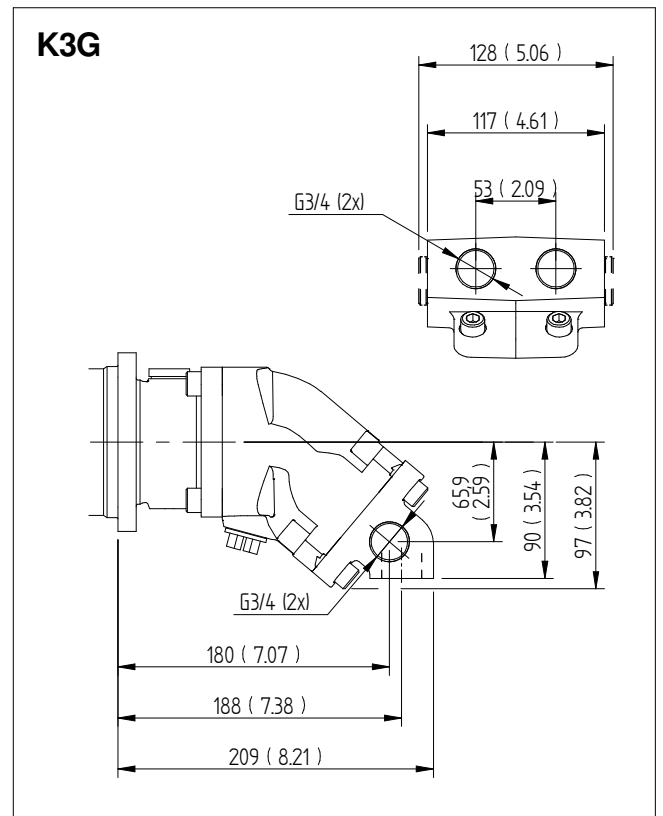
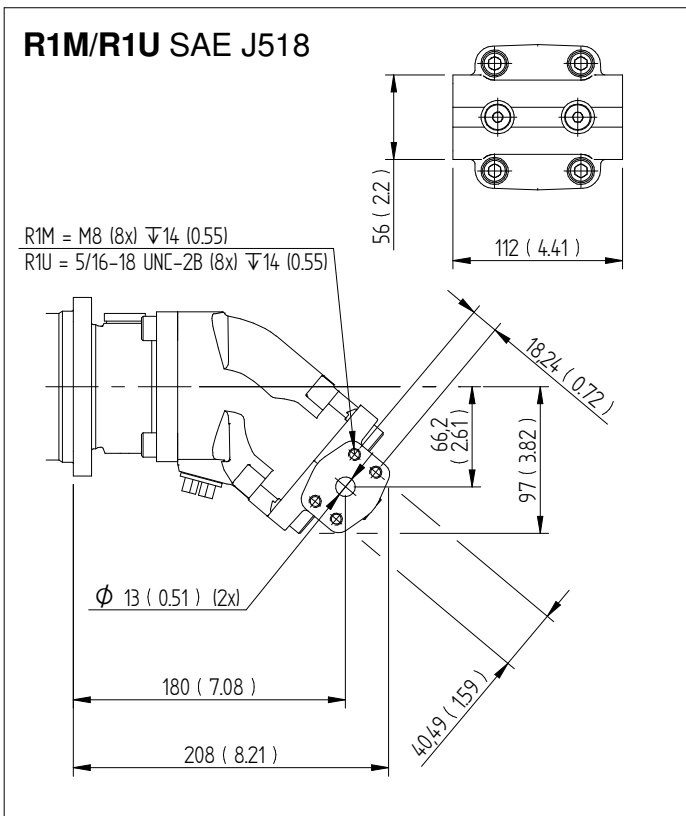
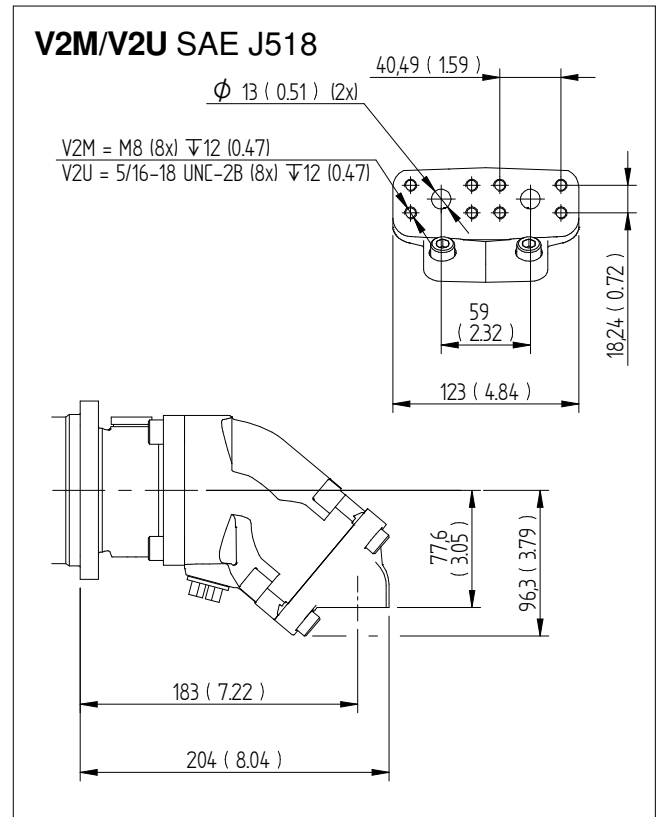
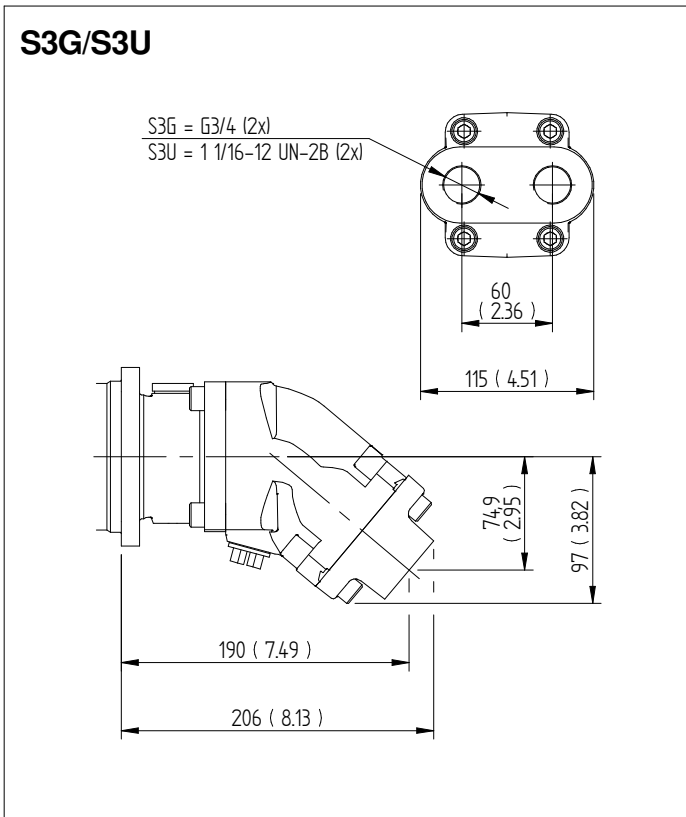

Dimensions SCM 025-034

Connection cover

Millimeter (inch)

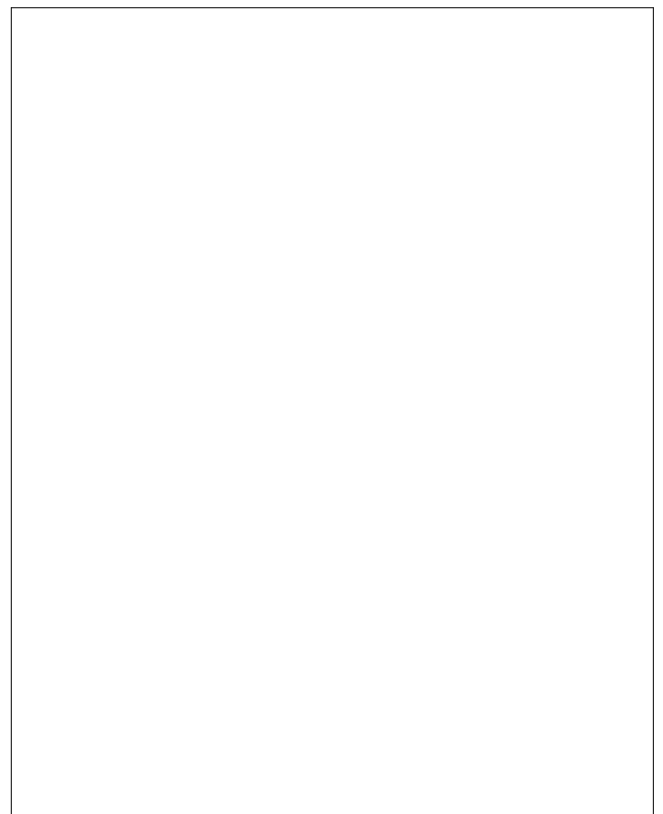
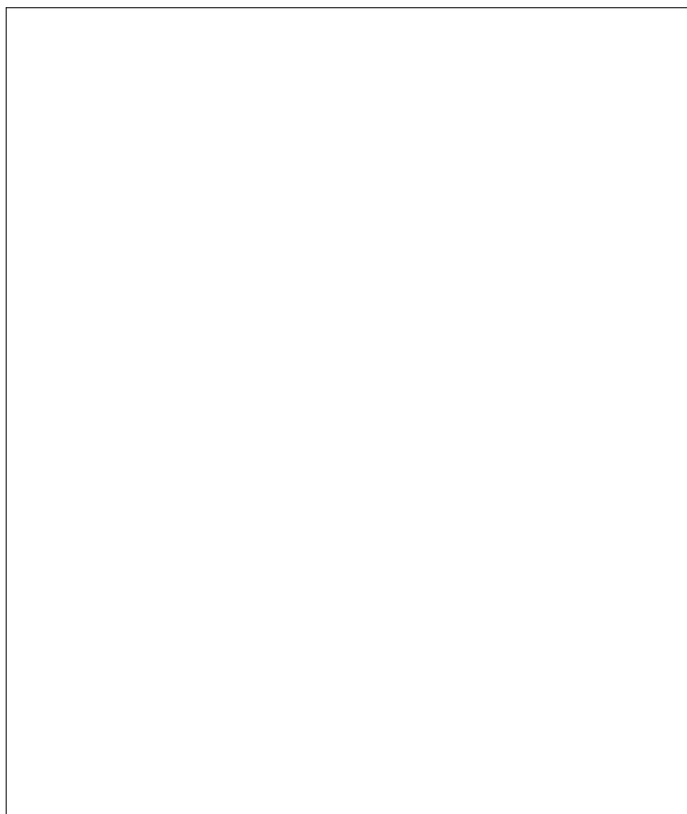
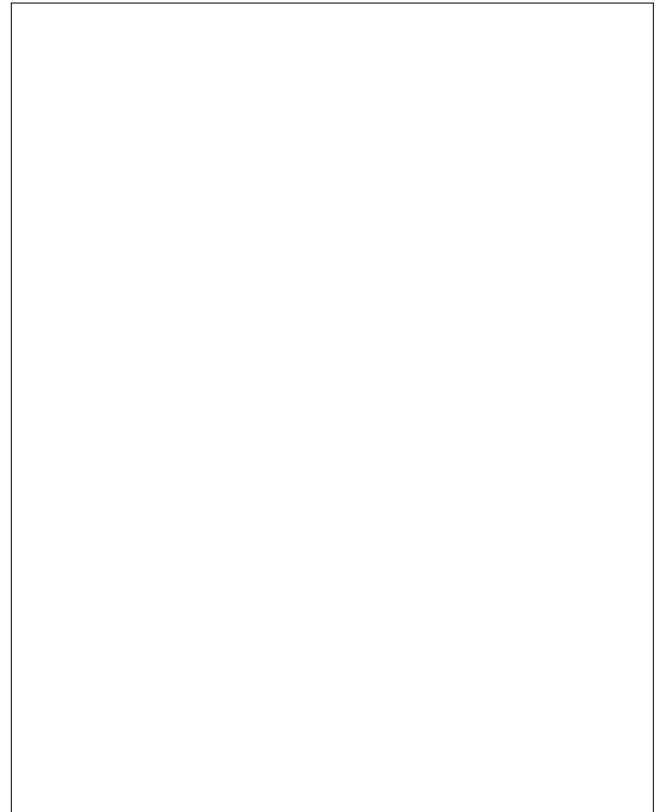
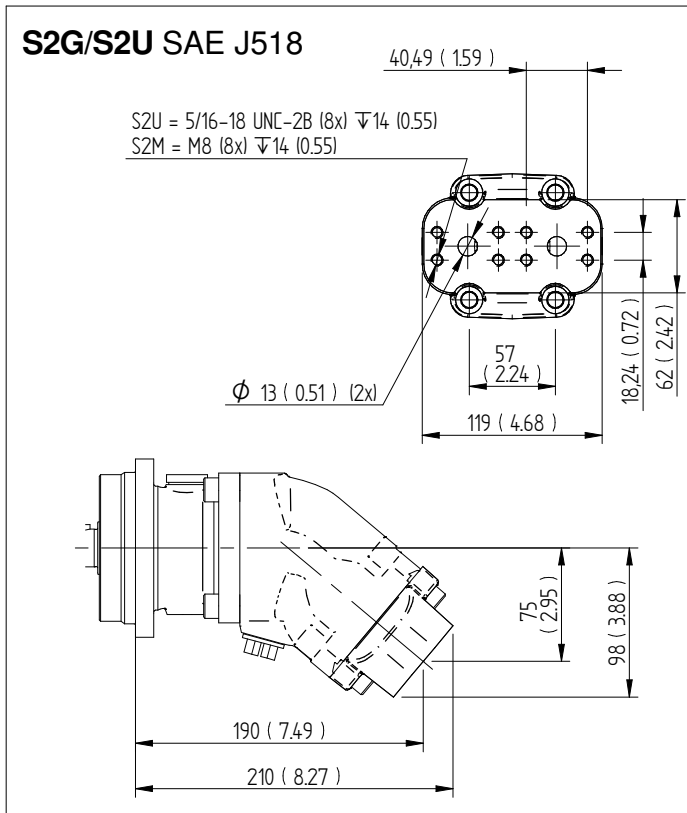

Dimensions SCM 040-064

Flange

Millimeter (inch)

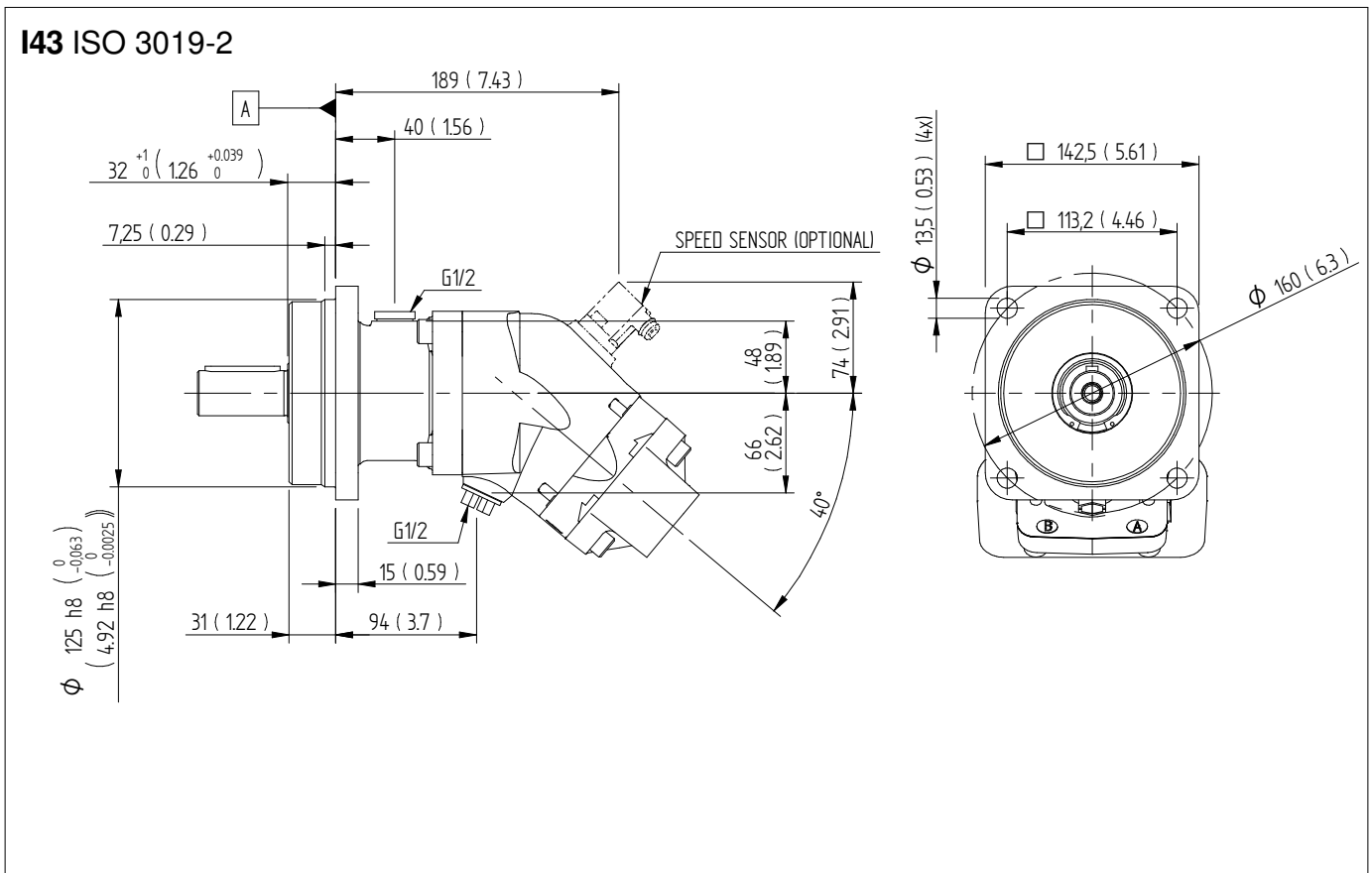

Dimensions SCM 040-064

Shafts

Millimeter (inch)

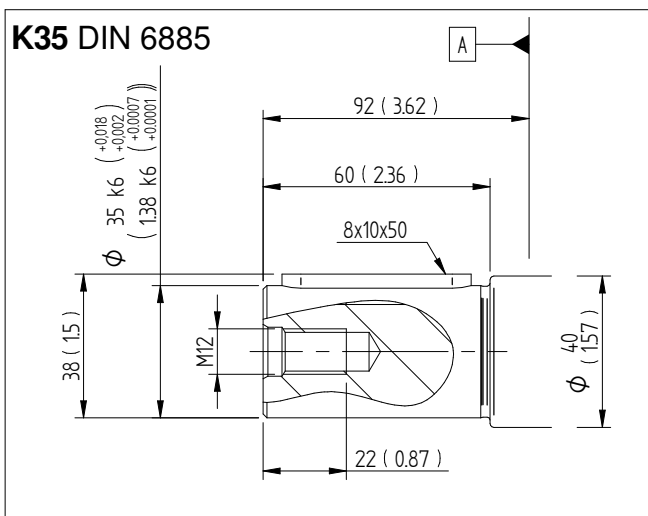
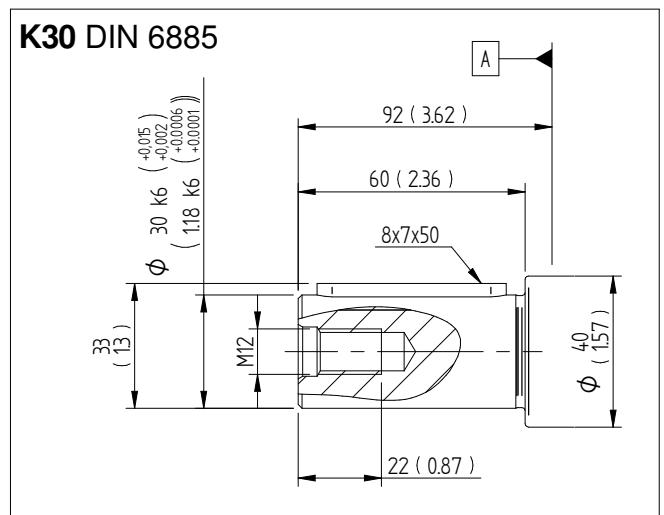
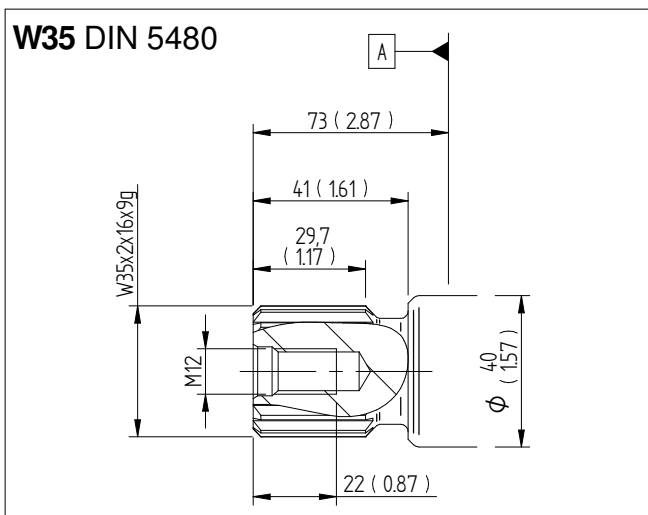
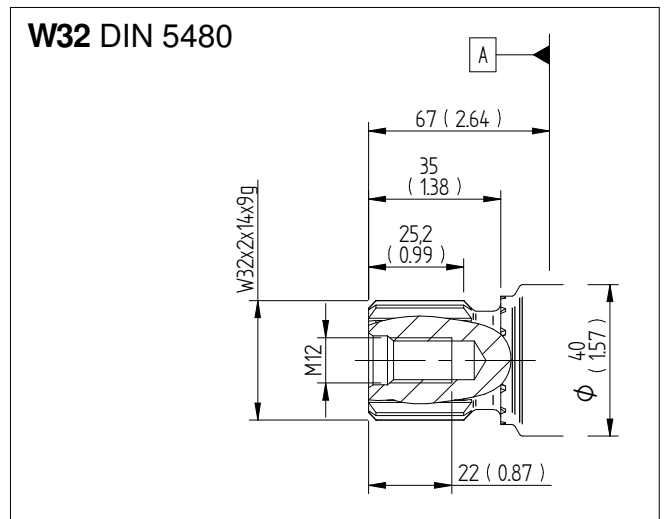
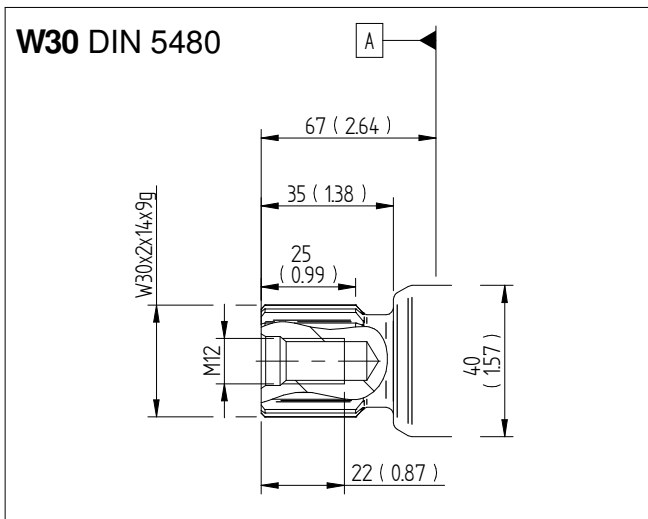

Dimensions SCM 040-064

Connection cover

Millimeter (inch)

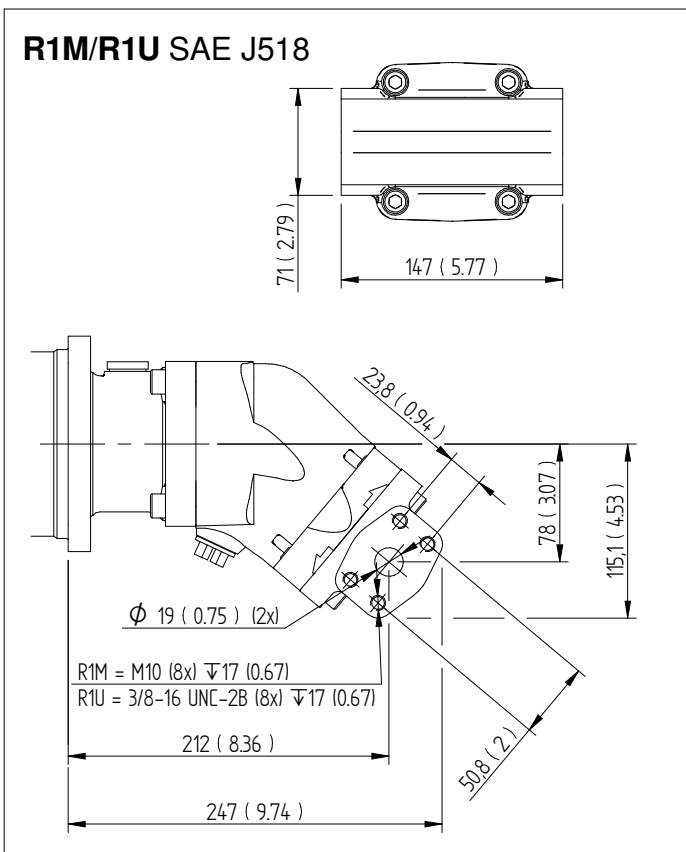
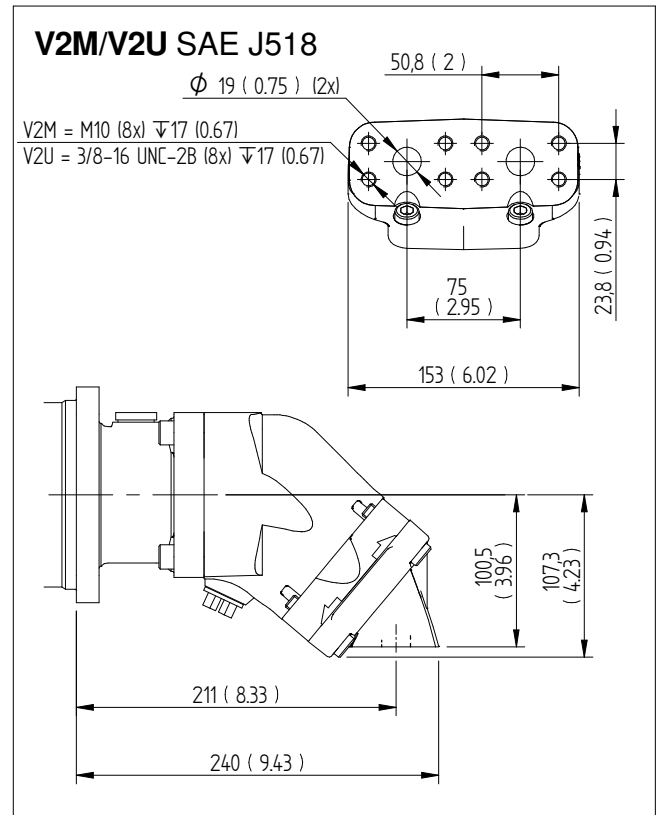
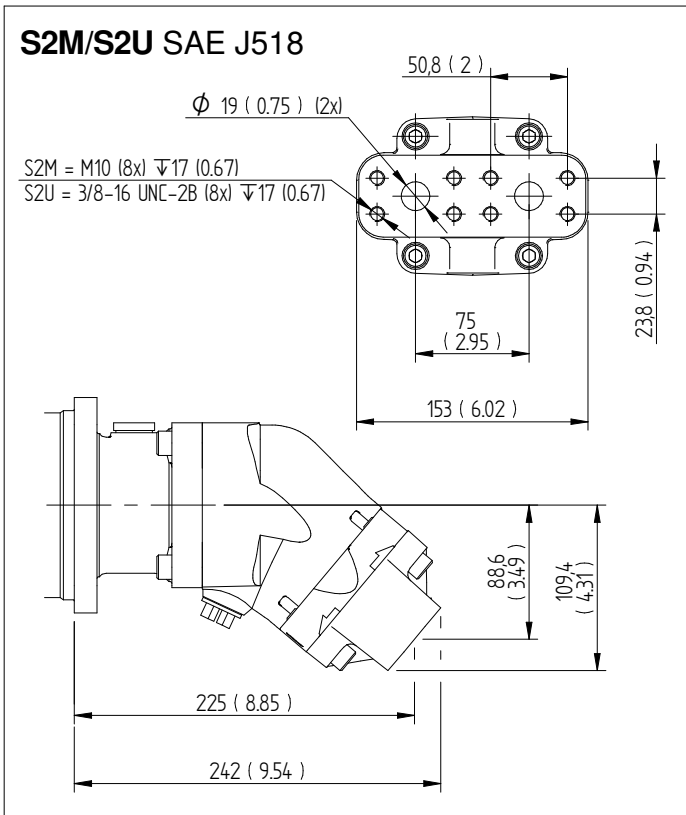

Dimensions SCM 084-090

Flange & shafts

Millimeter (inch)

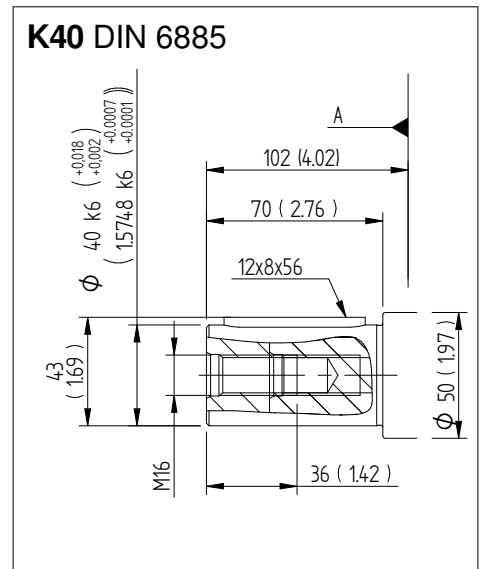
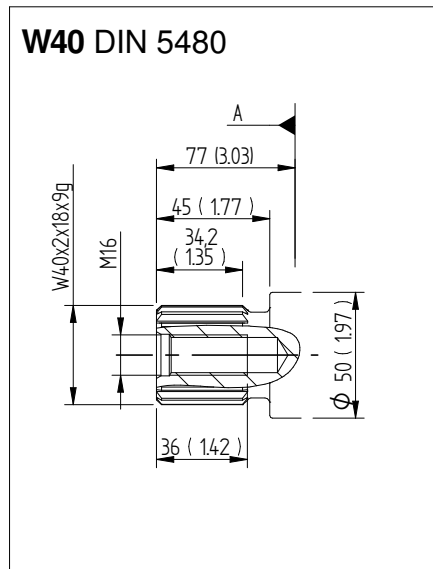
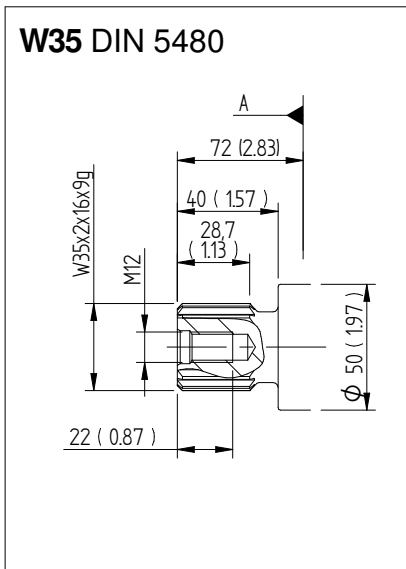
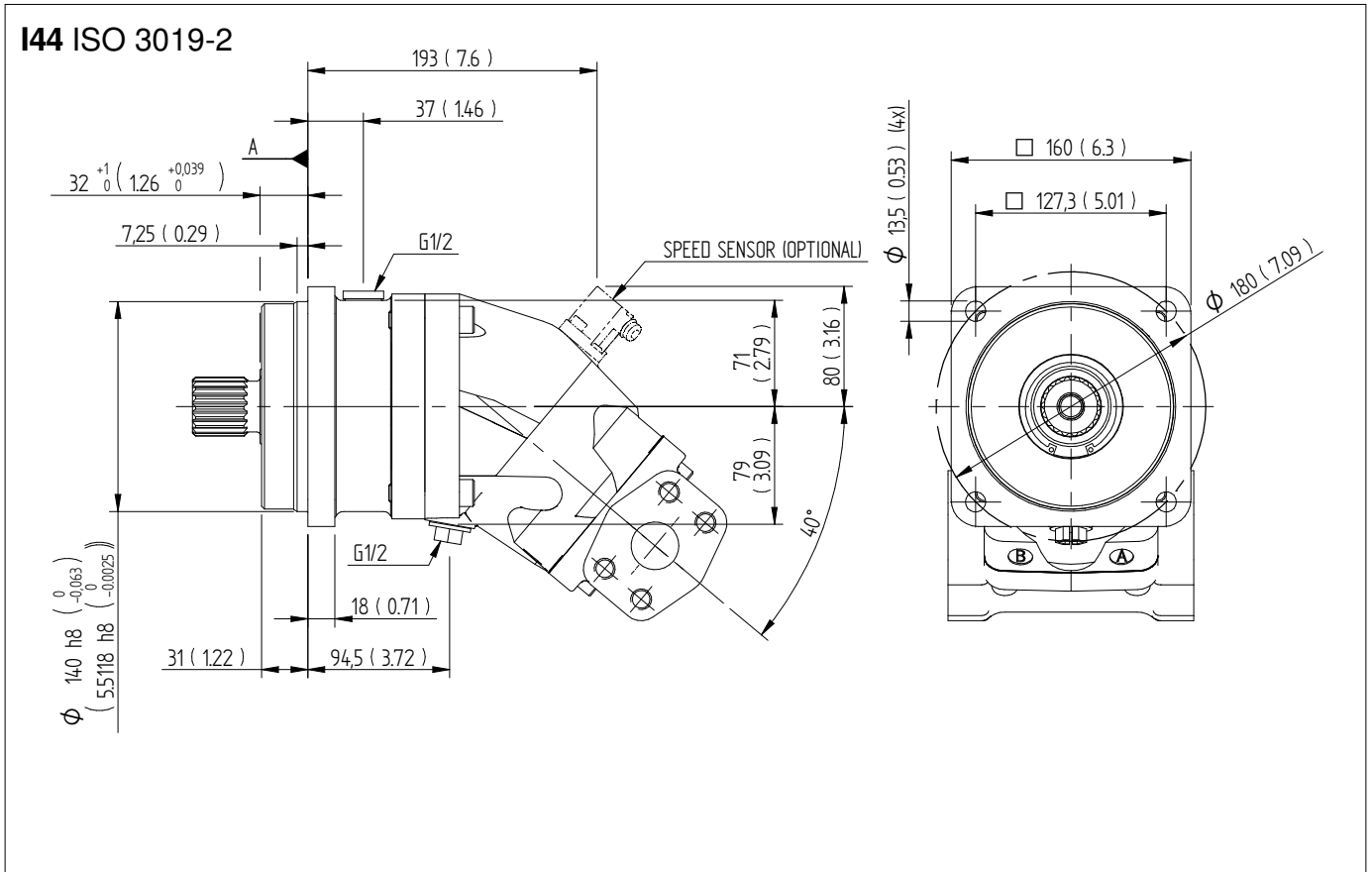

Dimensions SCM 084-090

Connection cover

Millimeter (inch)

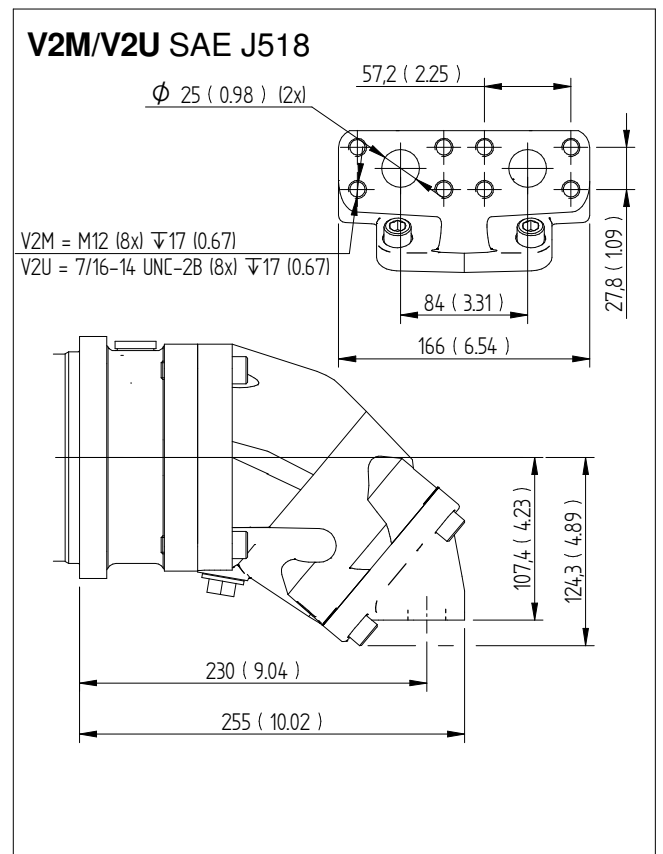
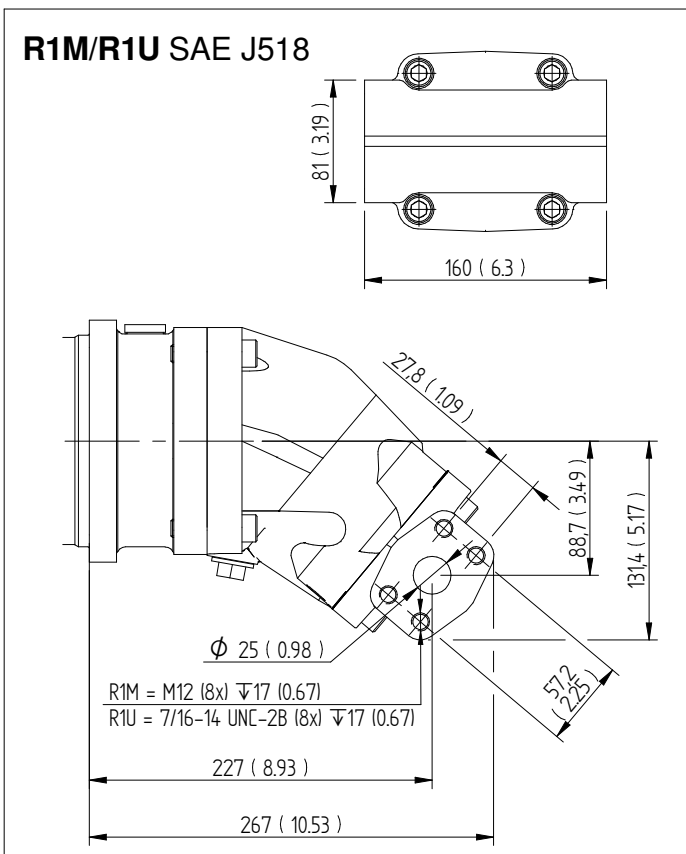
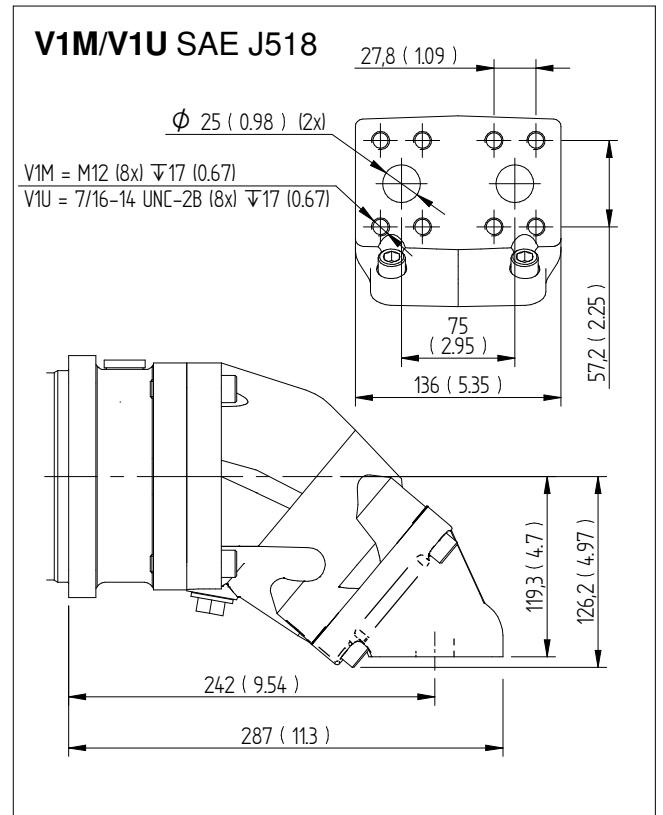
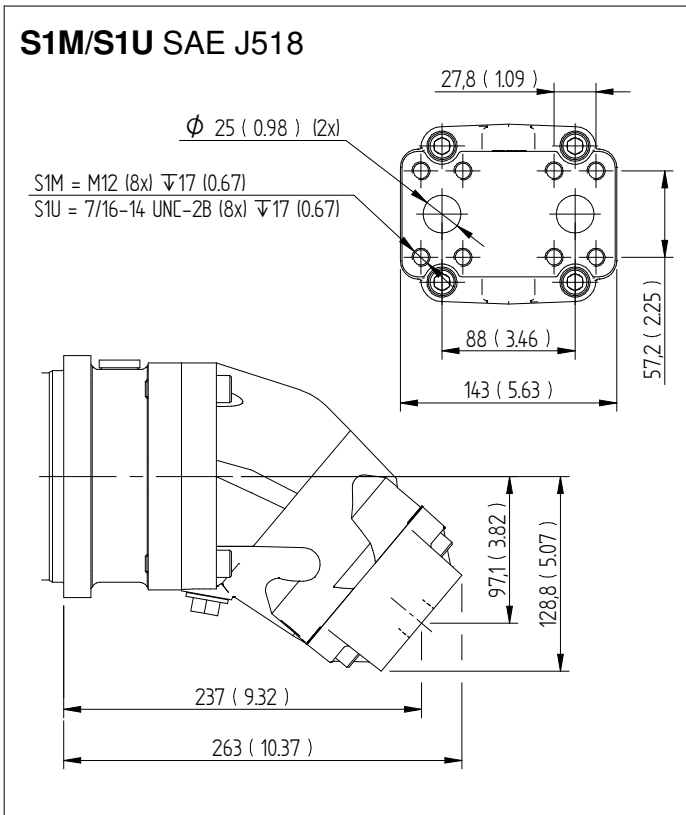

Dimensions SCM 108-130

Connection cover

Millimeter (inch)

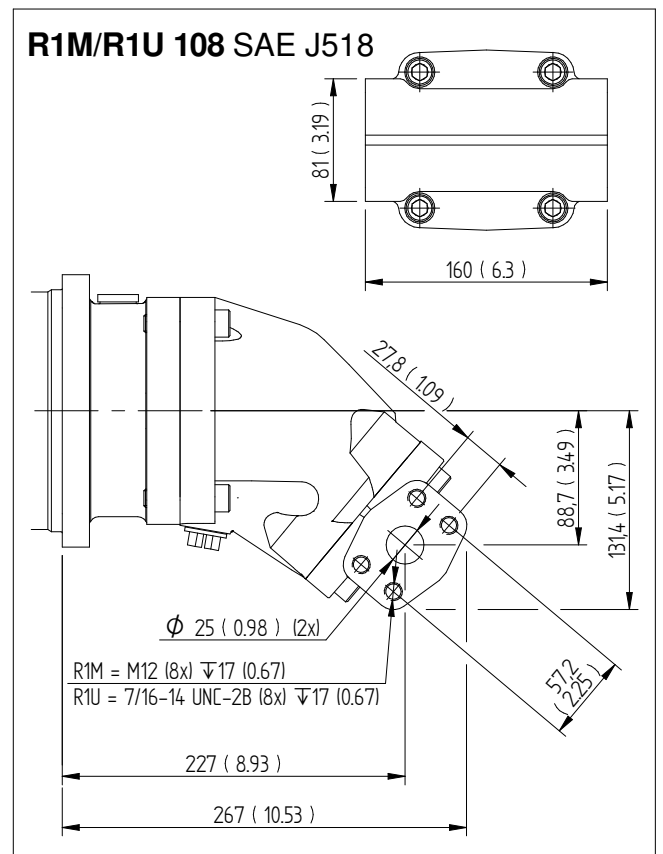
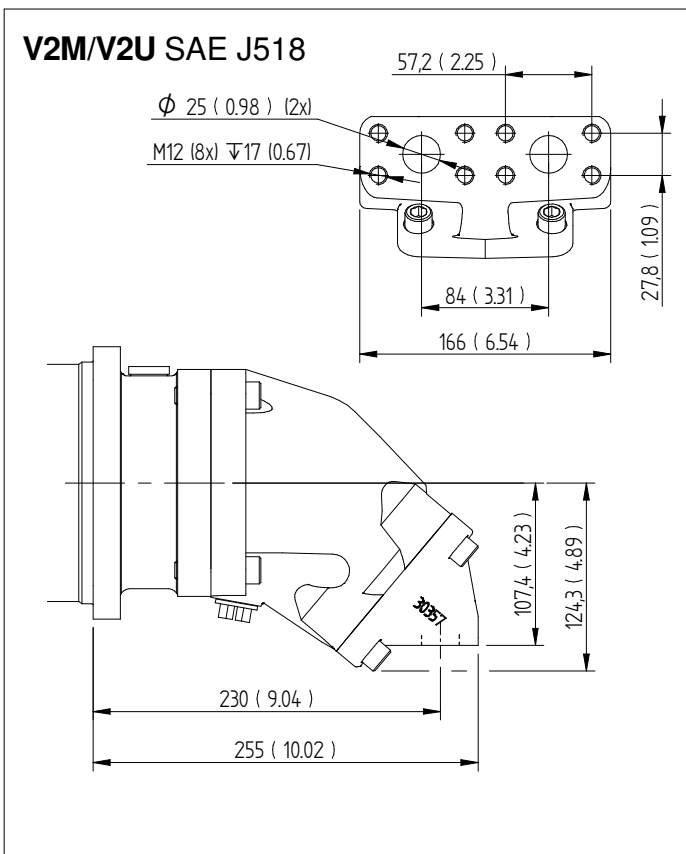
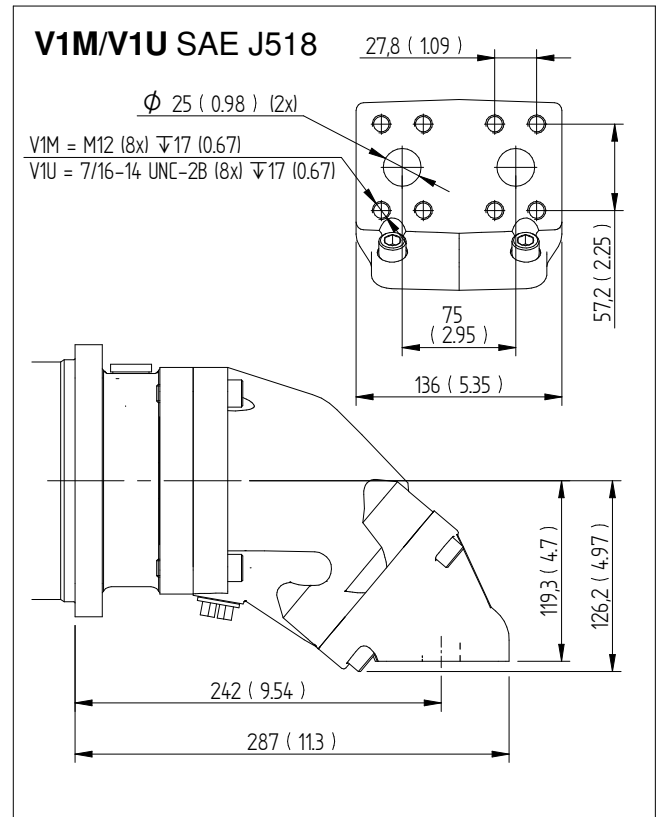
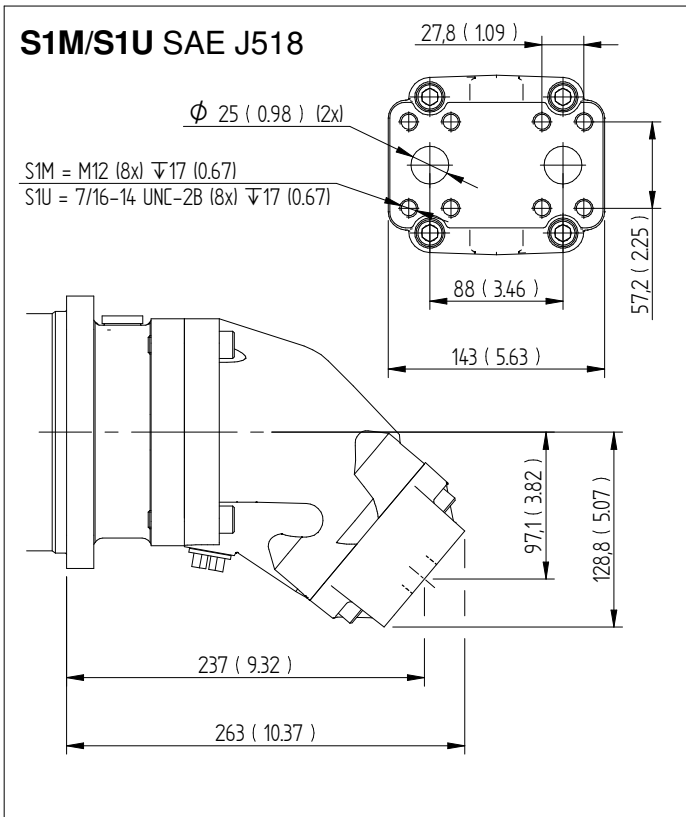

Dimensions SCM 108-130

Connection cover

Millimeter (inch)

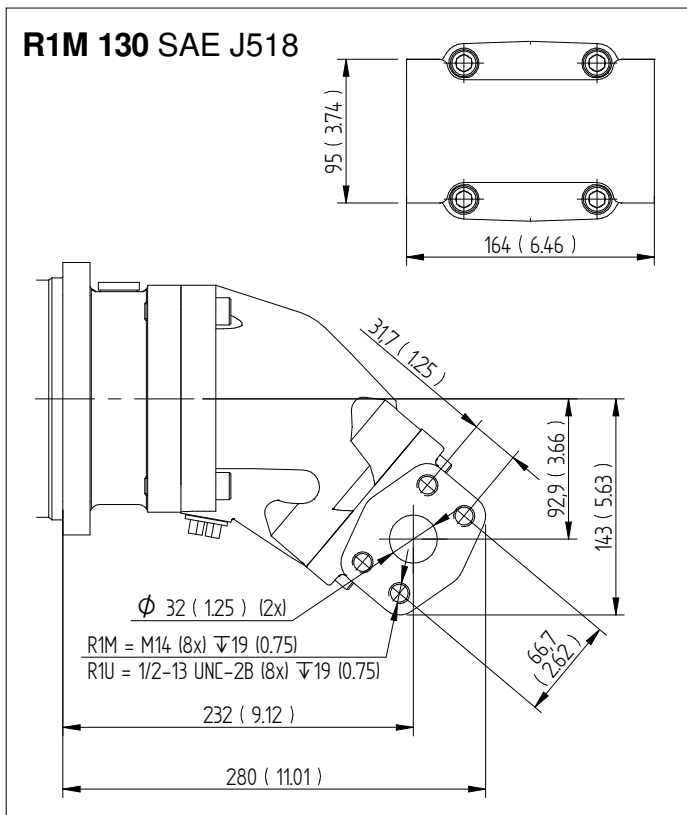

General instructions

Shaft seal

Motor SCM	Code	Max. housing pressure bar at rpm				
		1500	3000	5200	6300	8800
010-034	P	7	7	4	3.5	2.5
040-064	P	7	6	3.5	3	-
084-130	P	7	4	3	-	-

Code according to page 2. Versions main data.

For low temperature applications, below -25 °C please contact Sunfab.

The drainage oil should have a maximum temperature of 115 °C with the P shaft seal. This temperature must not be exceeded.

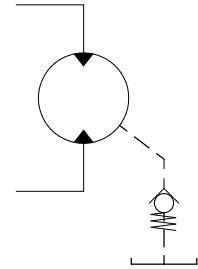

The housing pressure must be equal to or greater than the external pressure on the shaft seal.

To ensure the function of the shaft seal and lubrication of the motor, we recommend a min. housing pressure of 0,5 bar. If needed, a spring loaded check valve of 0,5 bar can be installed on the housing drain line.

Shaft loads

The life of the motor is highly dependent on the bearing life. The bearings are affected by operating conditions such as speed, pressure, oil viscosity and filtration.

External load on the shaft, as well as its size, direction and location also affects the bearing life.

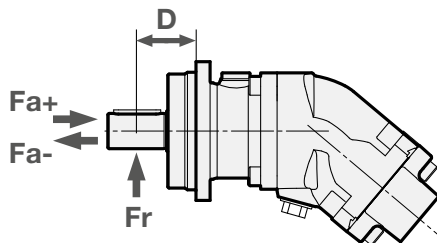

Optimal force direction of radial load

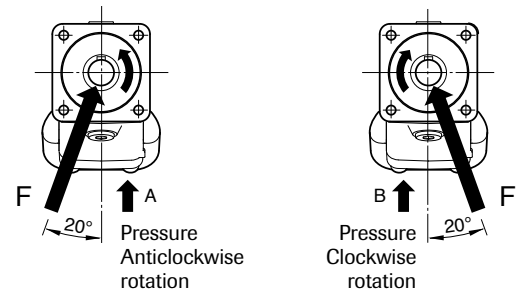

SCM ISO Max recommended shaft loads		010	012	017	025	034	040	047	056	064	084	090	108	130
Fr (radial) max ¹	kN	7	7	7	8	8	8.5	8.5	9	9	12	12.5	12.5	13
Distance D (to point of force)	mm	45	45	45	50	50	60	60	60	60	65	65	70	70
Fa (axial) + (at standstill/ 0 bar pressure) max	kN	3	3	3	3	3	4	4	4	4	5	5	5	5
Fa (axial) - (at standstill/ 0 bar pressure) max	kN	4	4	5	7	7	7	7	10	11	13	14	16	19
Fa (axial) + (at 400 bar pressure) max ²	kN	4	4	5	7	7	7	7	10	11	13	14	16	19
Fa (axial) - (at 400 bar pressure) max ²	kN	0	0	0	0	0	0	0	0	0	0	0	0	0

¹) Fr (radial) max; Calculation based on running conditions: 300 bar / 2000 rpm
¹) Fr (radial) max; Calculation based on optimal force direction (Fr max will be lower in other force directions)

¹) Fr (radial) max; In running conditions higher than 300 bar and/or 2000 rpm the max limits for Fr (radial) max will be lower

²) Fa (axial) + Will increase bearing life

²) Fa (axial) - Will decrease bearing life

For other forces, please contact Sunfab for advice.

Temperatures/Housing cooling

Excessive system temperature reduces the life of the shaft seal and can lower the oil viscosity below the recommended level. A system temperature of 60 °C and a drain flow temperature of 115 °C must not be exceeded.

Cooling/flushing of the motor housing can be needed to keep the drain flow temperature at an acceptable level.

Suggested flow:

Motor SCM	Flushing l/min	Cont. RPM
010-034	2-8	≥ 2800
040-064	4-10	≥ 2500
084-130	6-12	≥ 2200

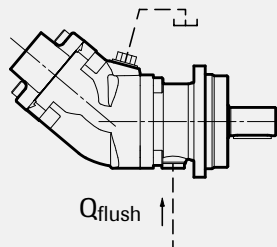

Housing flushing can be built up with the help of a flushing valve or taken directly from the return line. When the return pressure is too low this is compensated for by a counter pressure valve. The tank line is connected to the highest point as in the figure.

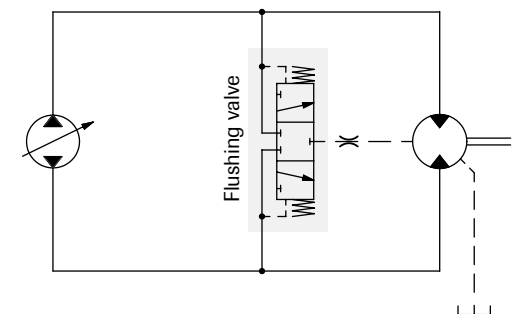
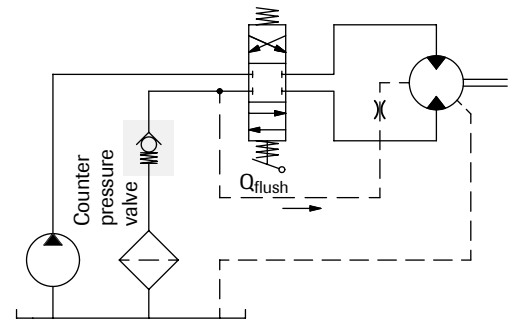
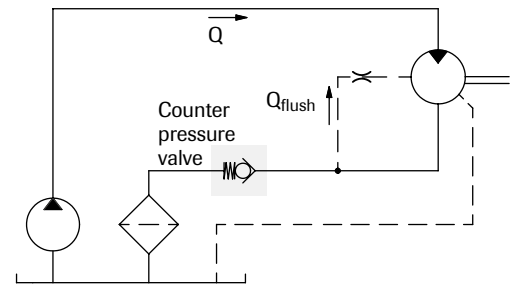

Simplified circuits

Installation

- The motor housing should be filled with oil to at least 50% before starting.
- The drainage pipe should be connected to topmost drainage outlet.
- The other end of the pipe should be connected to the oil tank at a point below the oil level.

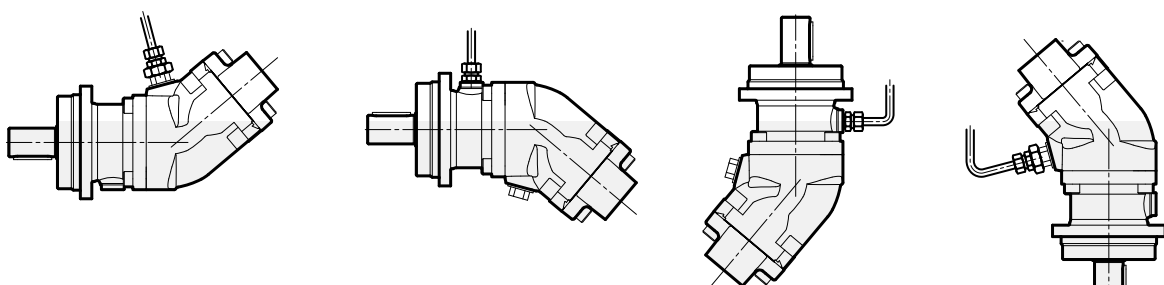

Piping

Recommended oil velocity in pressure line max. 7 m/sec

Filtering

Cleanliness according to ISO norm 4406, code 16/13.

Hydraulic fluids

High performance oils meeting ISO specifications – such as HM, DIN 51524-2 HLP, or better – must be used.

A min. viscosity of 10 cSt is required to keep the lubrication at a safe level.

The ideal viscosity is 20 - 40 cSt.

Additional technical data

Noise levels and bearing life calculations available on request. Please contact Sunfab!

Useful formulae

Required flow rate $Q = \frac{D \times n}{1000 \times \eta_v}$ litres/min.

Speed $n = \frac{Q \times 1000 \times \eta_v}{D}$ RPM

Torque $M = \frac{D \times \Delta p \times \eta_{hm}}{6.3}$ Nm

Power $P = \frac{Q \times \Delta p \times \eta_t}{60}$ kW

D = displacement, cm³/revolution

n = speed, revolution/min

P = power, kW

Q = flow rate, litres/min

η_v = volumetric efficiency

η_{hm} = hydraulic-mechanical efficiency

η_t = overall efficiency = $\eta_v \times \eta_{hm}$

M = torque, Nm

Δp = pressure difference between the hydraulic motor inlet and outlet, MPa



WARNING!

When the motor is in use:

1. Do not touch the pressure pipe
2. Watch out for rotating parts
3. The motor and pipes can reach high temperatures

Sunfab reserves the right to make changes in design and dimensions without notice. Printing and typesetting errors reserved.

© Copyright 2022 Sunfab Hydraulics AB. All Rights Reserved.